

This catalog covers:
FS481V-□S10

GRID NO. This grid covers:
A-01 TITLE

PARTS CATALOG

4-STROKE ENGINE

FS481V

PRODUCT CODE	NOTE
FS481V-AS10	STD (VARIOUS)
FS481V-BS10	

PARTS CATALOG INTRODUCTION

This parts catalog lists parts and sub-assemblies provided as service parts. When it becomes necessary to replace parts, always use KAWASAKI GENUINE PARTS which have passed strict inspection which guarantees quality and performance.

1. HOW TO ORDER PARTS

- When ordering the parts, be sure to use the parts catalog corresponding to the product code. Check the product revision codes on the product and the catalog.
 Product Code (example) : FA130D-AA00
 Product Revision Code
- Specify the part code (all digits) exactly as listed in this catalog on your parts order.
- The parts not shown in the illustrations of this catalog are not sold separately; only the complete units or next higher assemblies illustrated are supplied as the service parts.

2. EXPLANATION OF PARTS CATALOG FORMAT

Ref. No.	Part No.	Description	Quantity	
			A	B
11004	11004-7001	GASKET-HEAD	2	2
11008	11008-7001	HEAD-COMP-CYLINDER#1	1	1
11008A	11008-7002	HEAD-COMP-CYLINDER#2	1	1
11022	11022-7001	CASE-ROCKER	2	2
11060	11060-7001	GASKET,ROCKER CASE	2	2
11060A	11060-7008	GASKET,CRANKCASE COVER	1	1
11060B	11060-7015	GASKET,BREATHER	1	1
13271	13271-7016	PLATE	1	1
13271A	13271-7016	PLATE	1	1
14690	14690-7001	COVER,BREATHER	1	1
49015	49015-6215	COVER,CRANKCASE	1	1
49109	49109-7002	ELEMENT-BREATHER	1	1
49120	49120-6119	CRANKCASE-COMP	1	1
92033	92033-7003	RING-SNAP	2	2
92043	92043-7001	PIN	6	6
92049	92049-7001	SEAL-OIL	4	4
92049A	92049-7002	SEAL-OIL	1	1
92049B	92049-7004	SEAL-OIL	1	1
92049C	92049-7005	SEAL-OIL	1	1
130	130B0612	BOLT-FLANGED	4	4
130A	130B0640	BOLT-FLANGED	4	4
130B	130T0850	BOLT-FLANGED	17	17
130C	130T0875	BOLT-FLANGED	2	2
172	172G0818	BOLT-STUD	4	4

1) Product Code

This code describes the product code covered by this catalog. The product revision code, which is a part of the product code, is omitted.

2) Part Group Title

This title is the representative name for the group of parts illustrated on the page.

3) Reference Number

The reference numbers are shown on the illustration and the list as the link between them.

4) Part Number

This is the key of your parts ordering. Three kinds of part number are used in this catalog.

- Structure 1
- Structure 2
- Standard Hardware Number (for bolts, nuts, washer, or the like)

5) Description and Additional Information

The part name, the location, the size, and the serial number as additional information, etc. are described here. Use them to find out and check the part required.

When a part number is changed without change of the product revision code and the changed parts are not interchangeable, the serial number of the product is noted as follows;

- (FA130 - 100001) : Affected units are from beginning of the product of the product code up to and including this serial number.
- (FA130 - 100002 -) : Affected units are from this serial number and above.
- (FA130 - 100002 - FA130 - 110001) : Affected units are in this serial number range.

6) Quantity

The figure shows quantity of the part required at the indicated position on the illustration and for the specified product revision code.

The asterisk (*) on this column means the part can be used as the substitute on the product and is supplied until the stock is exhausted.

Note:Some small parts will be supplied by units.

Example: If six (6) bolts are ordered and the minimum quantity per unit is five (5), two (2), units of the bolt will be delivered.

7) Product Revision Code

This Code indicates an important change which affects the service parts interchangeability.

3. ABBREVIATIONS

#.....Number	FR.....Front	RH.....Right Hand
&.....And	G.....Gram	RPM.....Revolutions Per Minute
(+).....Plus	HEX.....Hexagonal	RR.....Rear
(-).....Minus	ID=.....Inside Diameter	STD.....Standard
2ND.....Second	IN.....Inch	T.....Teeth
3RD.....Third	L=.....Length	T=.....Thickness
4TH.....Fourth	LH.....Left Hand	U/S.....Under Size
A.....Ampere	LWR.....Lower	UPP.....Upper
AR.....As Required	MM.....Millimeter	V.....Volt
ASSY.....Assembly	O/S.....Over Size	W.....Watt
CNT.....Center	OD=.....Outside Diameter	
COMP.....Complete	REF.....Reference	

This catalog covers:
FS481V- □ S10

GRID NO. This grid covers:
B-01 PICTORIAL INDEX

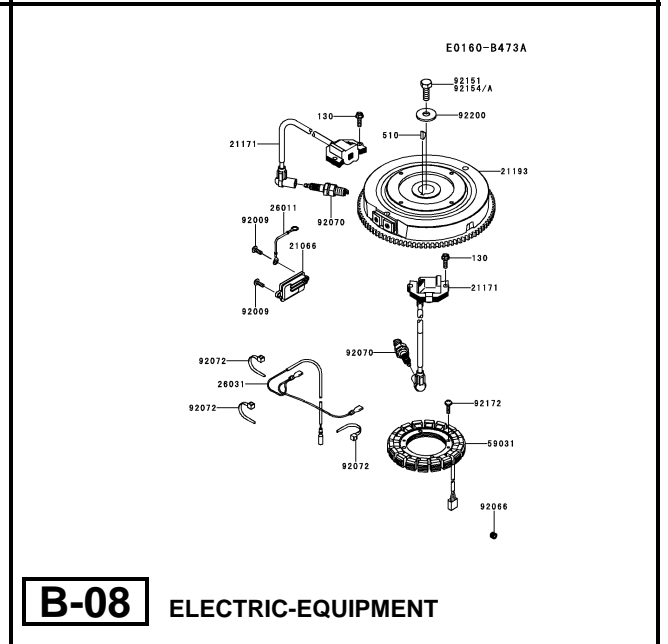
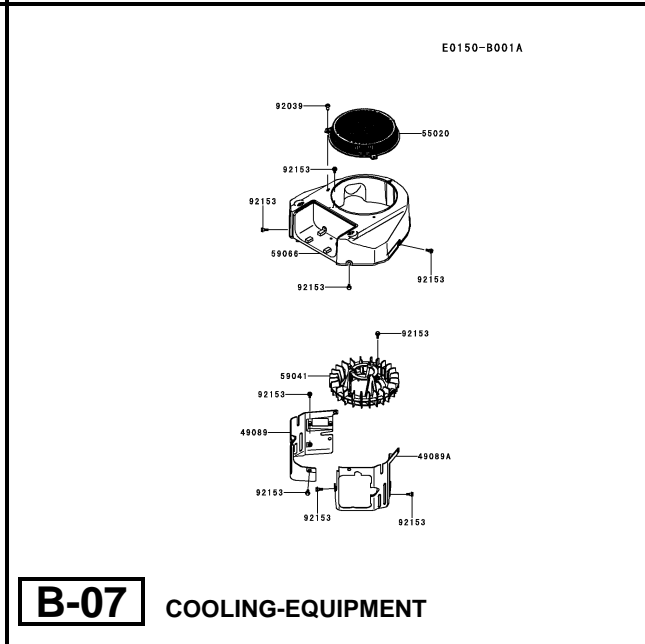
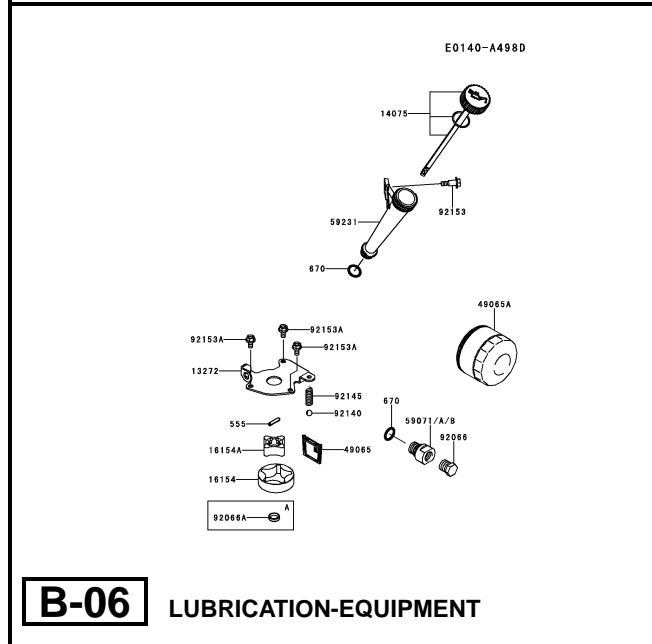
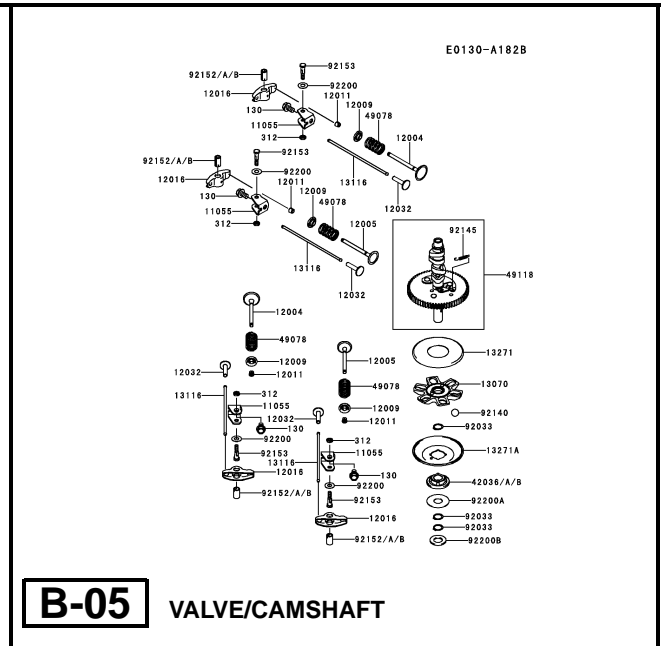
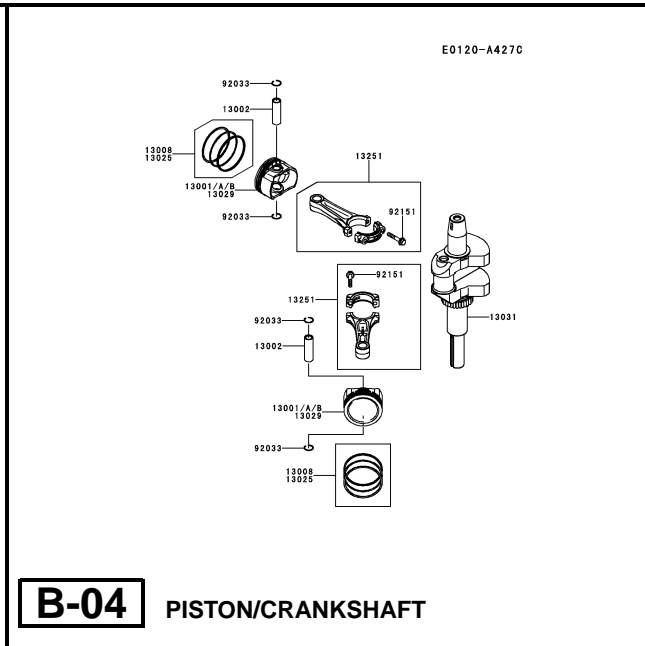
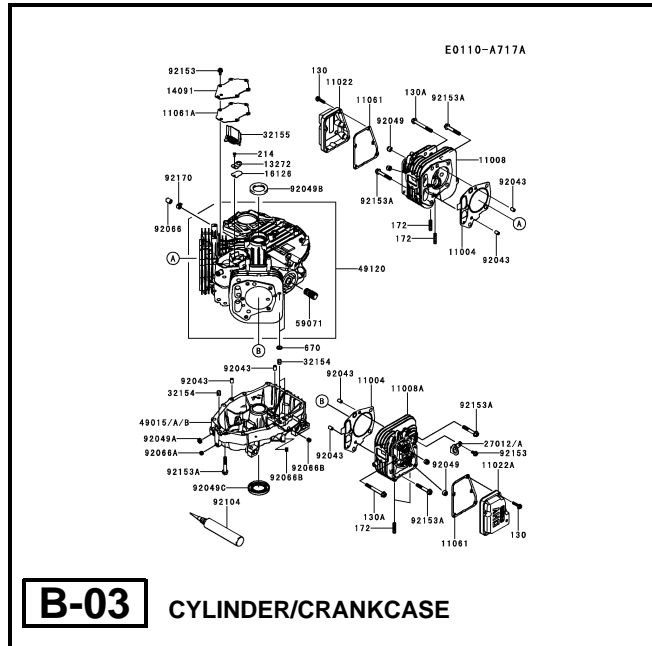

This catalog covers:

FS481V- □ S10

GRID NO.

B-02

This grid covers:

PICTORIAL INDEX

E0170-A708E

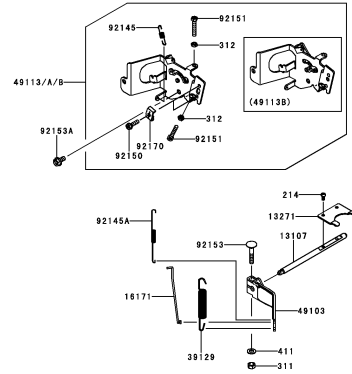

B-09

CONTROL-EQUIPMENT

E0180-A868B

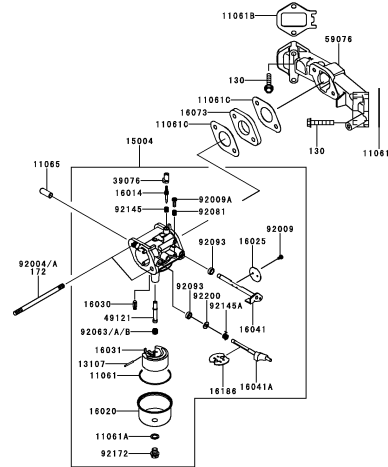

B-10

CARBURETOR

E0190-B230A

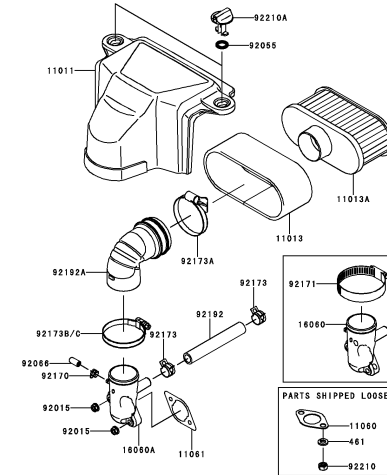

B-11

AIR-FILTER/MUFFLER

This catalog covers:

FS481V- □ S10

GRID NO.

C-01

This grid covers:

PICTORIAL INDEX

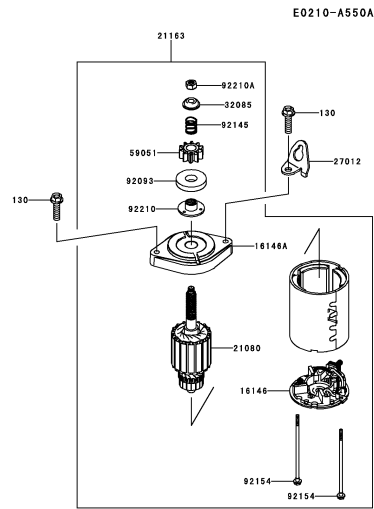

C-03

STARTER

This catalog covers:

FS481V- □ S10

GRID NO.

D-01

This grid covers:

PICTORIAL INDEX

F0290-B469A

56033

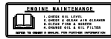

56070



D-03

LABEL

This catalog covers:
FS481V- □ S10

GRID NO. This grid covers:

B-03 **CYLINDER/CRANKCASE**

E0110-A717A

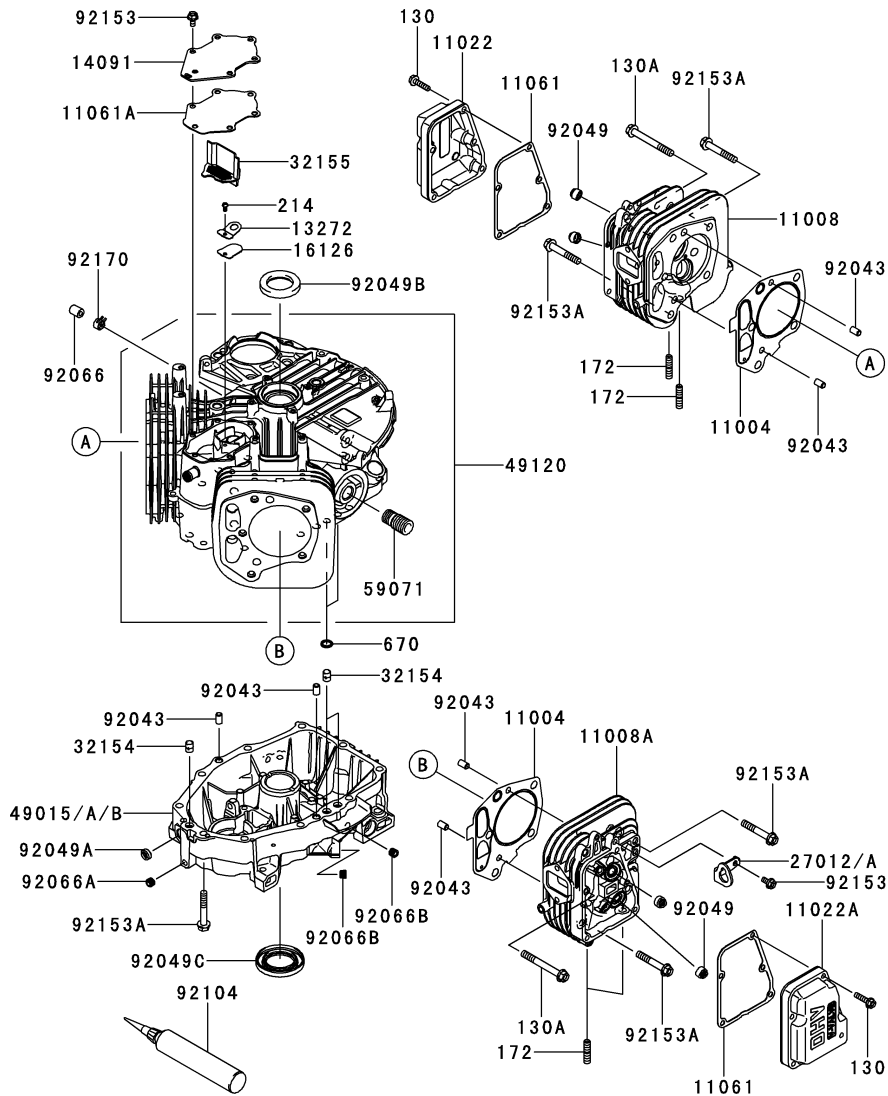

Ref. No.	Part No.	Description	Quantity	
			A	B
11004	11004-7027	GASKET-HEAD	2	2
11008	11008-7050	HEAD-COMP-CYLINDER,#1	1	1
11008A	11008-7051	HEAD-COMP-CYLINDER,#2	1	1
11022	11022-7019	CASE-ROCKER,#1	1	1
11022A	11022-7020	CASE-ROCKER,#2	1	1
11061	11061-7083	GASKET,CASE-ROCKER	2	2
11061A	11061-7094	GASKET,BREATHER	1	1
13272	13272-7004	PLATE,BREATHER	1	1
14091	14091-7064	COVER,BREATHER	1	1
16126	16126-7020	VALVE,BREATHER	1	1
27012	27012-0721	HOOK,LIFT	1	1
27012A	27012-7007	HOOK,LIFT	*	*
32154	32154-7019	PIPE	3	3
32155	32155-7003	PIPE,BREATHER	1	1
49015	49015-7083	COVER-CRANKCASE	*	
49015A	49015-7104	COVER-CRANKCASE		1
49015B	49015-7104	COVER-CRANKCASE	1	
49120	49120-7135	CRANKCASE-COMP	1	1
59071	59071-2079	JOINT	1	1
92043	92043-1263	PIN	6	6
92049	92049-7001	SEAL-OIL,RVC2 6X11X10.2	4	4
92049A	92049-7005	SEAL-OIL,SO 8X14X5 HS	1	1
92049B	92049-7010	SEAL-OIL,SD 35X48X8 R HS	1	1
92049C	92049-7028	SEAL-OIL,38X62X8MTCLV	1	1
92066	92066-2096	PLUG	1	1
92066A	92066-7023	PLUG	1	1
92066B	92066-7026	PLUG	2	2
92104	92104-7001	GASKET-LIQUID,TB1217H	AR	AR
92153	92153-7043	BOLT,6X12	7	7
92153A	92153-7054	BOLT,8X50	14	14
92170	92170-2088	CLAMP	1	1
130	130AA0625	BOLT-FLANGED,6X25	10	10
130A	130CA0870	BOLT-FLANGED,8X70	6	6
172	172BA0818	BOLT-STUD,8X18	4	4
214	214AA0408	SCREW-PAN+,-,4X8	1	1
670	670B2011	O RING,11MM	2	2

This catalog covers:

FS481V- □ S10

GRID NO.

B-04

This grid covers:

PISTON/CRANKSHAFT

E0120-A427C

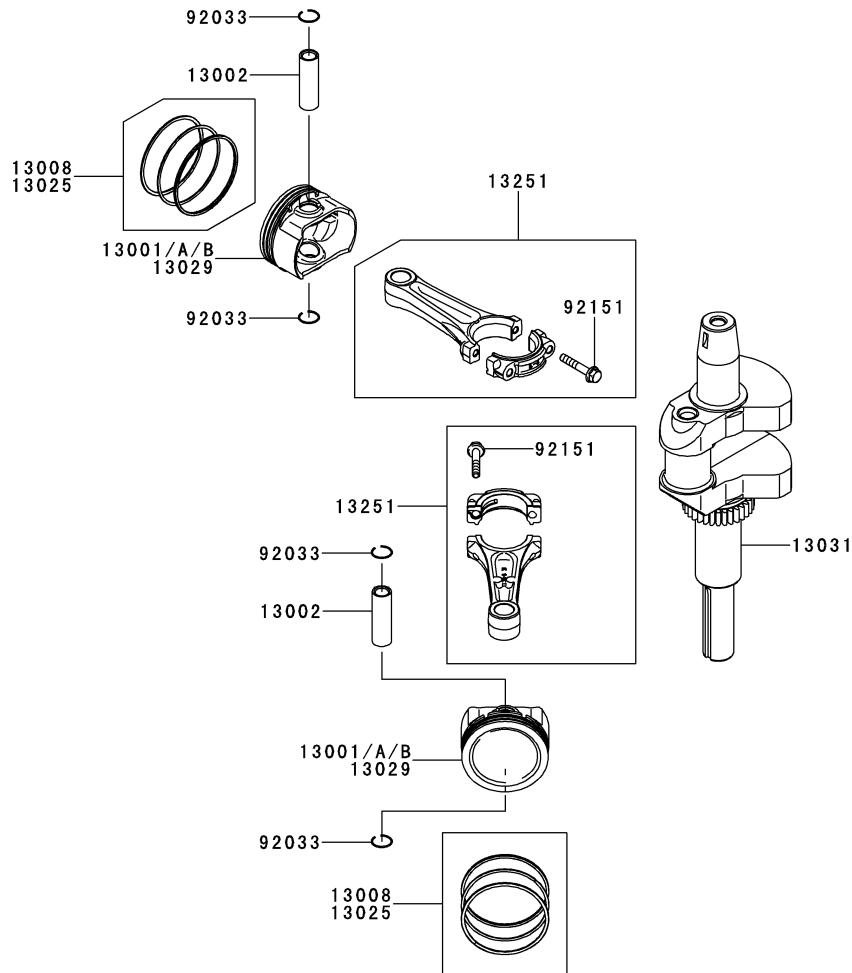

Ref. No.	Part No.	Description	Quantity	
			A	B
13001	13001-7028	PISTON-ENGINE	*	
13001A	13001-7031	PISTON-ENGINE		2
13001B	13001-7031	PISTON-ENGINE	2	
13002	13002-7001	PIN-PISTON	2	2
13008	13008-7006	RING-SET-PISTON	2	2
13025	13025-7010	RING-SET-PISTON L,0.50	AR	AR
13029	13029-7011	PISTON-ENGINE L,0.50	AR	AR
13031	13031-7090	CRANKSHAFT-COMP	1	1
13251	13251-7021	ROD-ASSY-CONNECTING	2	2
92033	92033-7002	RING-SNAP	4	4
92151	92151-7017	BOLT,6X35	4	4

This catalog covers:

FS481V- □ S10

GRID NO.

B-05

This grid covers:

VALVE/CAMSHAFT

E0130-A182B

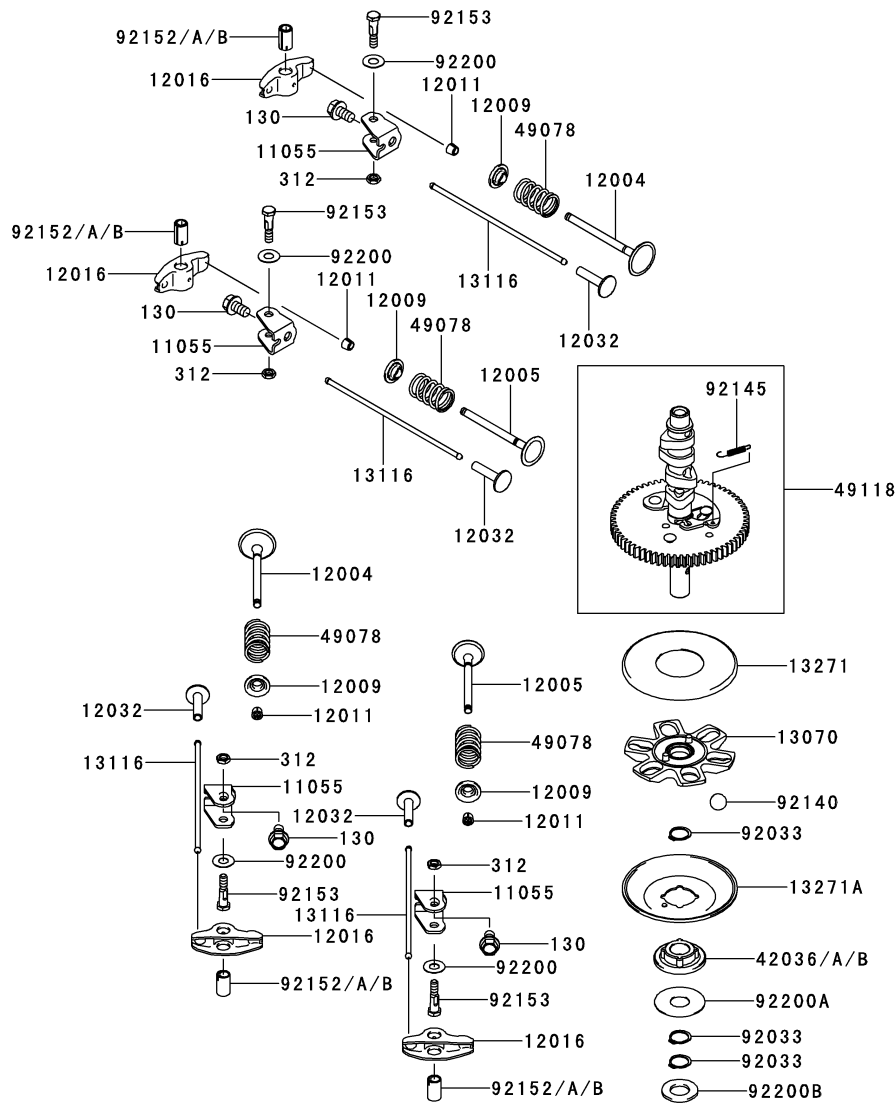

Ref. No.	Part No.	Description	Quantity	
			A	B
11055	11055-7009	BRACKET	4	4
12004	12004-7009	VALVE-INTAKE	2	2
12005	12005-7010	VALVE-EXHAUST	2	2
12009	12009-7001	RETAINER-VALVE SPRING	4	4
12011	12011-2056	COLLET	8	8
12016	12016-2066	ARM-ROCKER	4	4
12032	12032-7001	TAPPET	4	4
13070	13070-7017	GUIDE,GOVERNOR	1	1
13116	13116-7008	ROD-PUSH	4	4
13271	13271-7007	PLATE	1	1
13271A	13271-7021	PLATE,GOVERNOR	1	1
42036	42036-7010	SLEEVE	*	
42036A	42036-7021	SLEEVE		1
42036B	42036-7021	SLEEVE	1	
49078	49078-7002	SPRING-ENGINE VALVE,IN	4	4
49118	49118-7023	CAMSHAFT-COMP	1	1
92033	92033-7001	RING-SNAP	3	3
92140	92140-7005	BALL	6	6
92145	92145-7001	SPRING	1	1
92152	92152-7020	COLLAR	*	
92152A	92152-7022	COLLAR		4
92152B	92152-7022	COLLAR	4	
92153	92153-7100	BOLT,6X29.5	4	4
92200	92200-2151	WASHER,8.1X18X0.5	4	4
92200A	92200-7009	WASHER,16X42X0.91	1	1
92200B	92200-7048	WASHER,16.3X30X2.28	1	1
130	130AA0814	BOLT-FLANGED,8X14	4	4
312	312AA0600	NUT-HEX,6MM	4	4

This catalog covers:
FS481V- □ S10

GRID NO. This grid covers:
B-06 LUBRICATION-EQUIPMENT

E0140-A498D

Ref. No.	Part No.	Description	Quantity	
			A	B
13272	13272-7011	PLATE, ROTOR	1	1
14075	14075-7013	CAP-ASSY, OIL GAUGE	1	1
16154	16154-7010	ROTOR-PUMP, OUTER	1	1
16154A	16154-7011	ROTOR-PUMP, INNER	1	1
49065	49065-7006	FILTER-OIL	1	1
49065A	49065-7007	FILTER-OIL	1	1
59071	59071-7004	JOINT	*	
59071A	59071-7023	JOINT		1
59071B	59071-7023	JOINT	1	
59231	59231-7016	FILLER	1	1
92066	92066-7006	PLUG	1	1
92066A	92066-7028	PLUG	1	
92140	92140-7003	BALL	1	1
92145	92145-7002	SPRING	1	1
92153	92153-7008	BOLT	1	1
92153A	92153-7043	BOLT, 6X12	3	3
555	555A0420	PIN-SPRING, 4X20	1	1
670	670D2016	O RING, 16MM	2	2

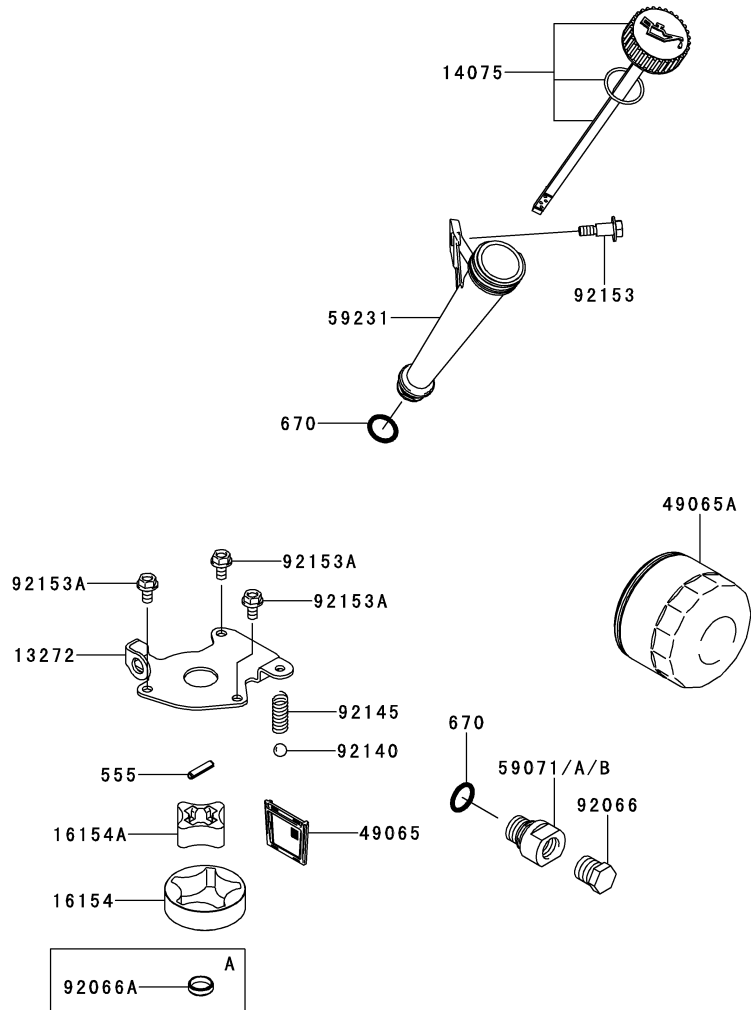

This catalog covers:

FS481V- □ S10

GRID NO.

B-07

This grid covers:

COOLING-EQUIPMENT

E0150-B001A

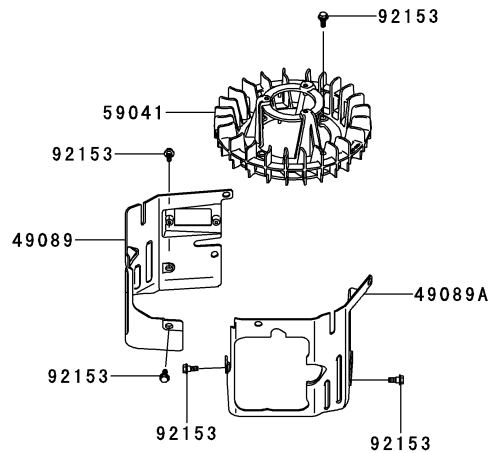
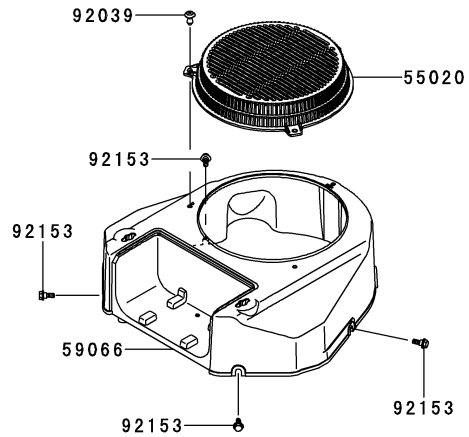

Ref. No.	Part No.	Description	Quantity	
			A	B
49089	49089-7083	SHROUD-ENGINE	1	1
49089A	49089-7084	SHROUD-ENGINE	1	1
55020	55020-7015	GUARD,SCREEN	1	1
59041	59041-7016	FAN	1	1
59066	59066-7055	HOUSING-FAN	1	1
92039	92039-7004	RIVET,GUARD	3	3
92153	92153-7007	BOLT	12	12

This catalog covers:

FS481V- □ S10

GRID NO.

B-08

This grid covers:

ELECTRIC-EQUIPMENT

E0160-B473A

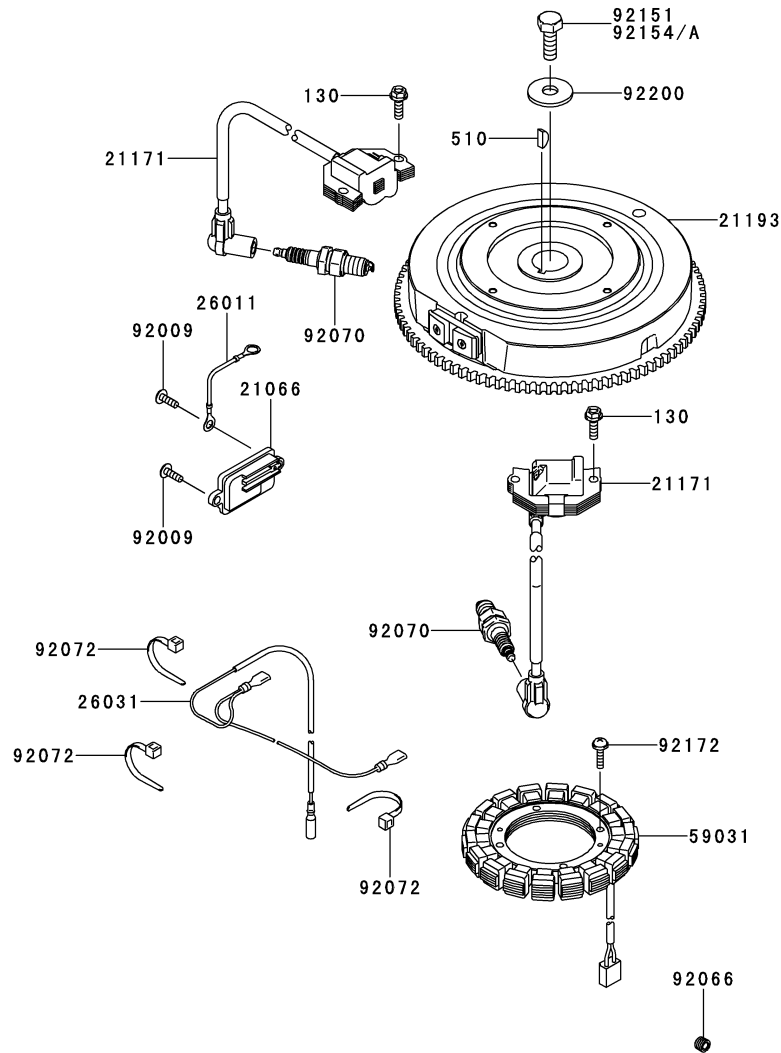

Ref. No.	Part No.	Description	Quantity	
			A	B
21066	21066-7017	REGULATOR-VOLTAGE	1	1
21171	21171-7047	COIL-ASSY-IGNITION	2	2
21193	21193-7038	FLYWHEEL-ASSY	1	1
26011	26011-7025	WIRE-LEAD,L=95	1	1
26031	26031-7040	HARNESS	1	1
59031	59031-7017	COIL-CHARGING	1	1
92009	92009-2303	SCREW	2	2
92066	92066-7026	PLUG	1	1
92070	92070-7004	PLUG-SPARK,BPR4ES(NGK),SOLID	2	2
92072	92072-7003	BAND	3	3
92151	92151-2097	BOLT,12X30	*	
92154	92154-7003	BOLT,12X30		1
92154A	92154-7003	BOLT,12X30	1	
92172	92172-7018	SCREW,5X20	4	4
92200	92200-7002	WASHER	1	1
130	130AA0620	BOLT-FLANGED,6X20	4	4
510	510A5100	KEY-WOODRUFF	1	1

This catalog covers:

FS481V- □ S10

GRID NO.

B-09

This grid covers:

CONTROL-EQUIPMENT

E0170-A708E

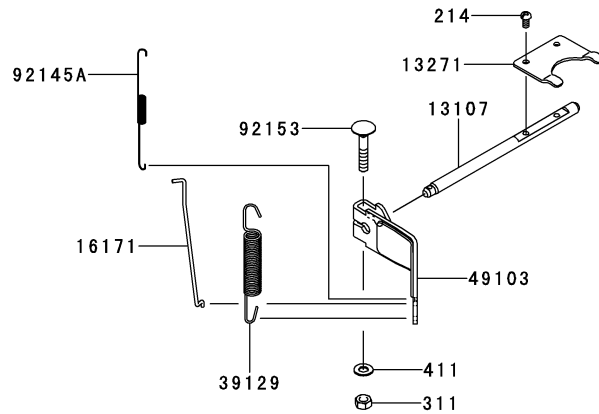
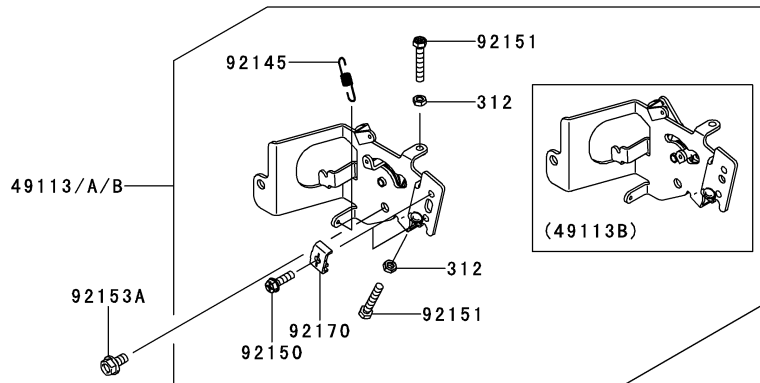

Ref. No.	Part No.	Description	Quantity	
			A	B
13107	13107-7049	SHAFT	1	1
13271	13271-7038	PLATE	1	1
16171	16171-7025	LINK	1	1
39129	39129-7033	SPRING-GOVERNOR	1	1
49103	49103-7017	ARM-GOVERNOR	1	1
49113	49113-0716	PANEL-COMP-CONTROL		1
49113A	49113-0716	PANEL-COMP-CONTROL	1	
49113B	49113-7061	PANEL-COMP-CONTROL	*	
92145	92145-7004	SPRING	1	1
92145A	92145-7057	SPRING	1	1
92150	92150-2182	BOLT,5X18	2	2
92151	92151-7014	BOLT,5X30	2	2
92153	92153-7033	BOLT,6X35	1	1
92153A	92153-7043	BOLT,6X12	1	1
92170	92170-7001	CLAMP	2	2
214	214AA0408	SCREW-PAN+-,4X8	2	2
311	311AA0600	NUT-HEX,6MM	1	1
312	312AA0500	NUT-HEX,5MM	2	2
411	411AA0600	WASHER-PLAIN,6MM	1	1

This catalog covers:
FS481V- □ S10

GRID NO. This grid covers:
B-10 CARBURETOR

E0180-A868B

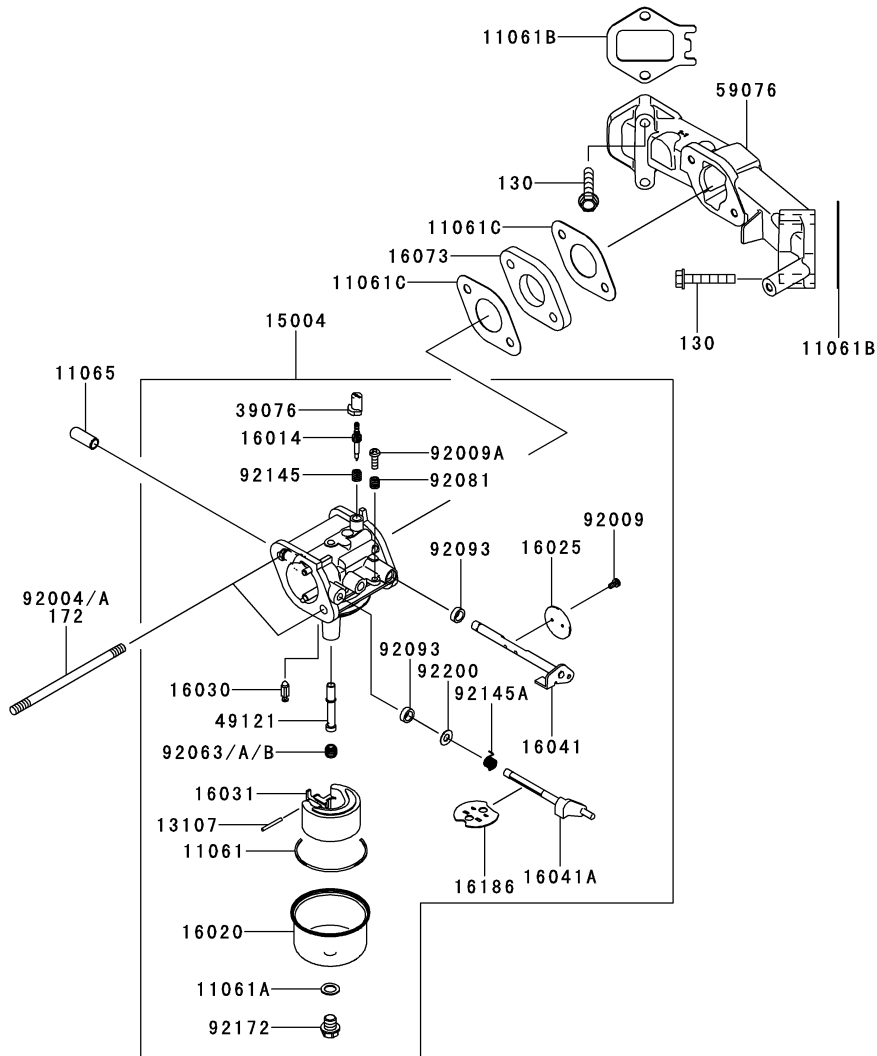

Ref. No.	Part No.	Description	Quantity	
			A	B
11061	11061-7009	GASKET,CHAMBER	1	1
11061A	11061-7010	GASKET,SCREW	1	1
11061B	11061-7089	GASKET,MANIFOLD	2	2
11061C	11061-7096	GASKET,INSULATOR	2	2
11065	11065-7005	CAP	1	1
13107	13107-7018	SHAFT	1	1
15004	15004-7086	CARBURETOR-ASSY	1	1
16014	16014-7011	SCREW-PILOT AIR	1	1
16020	16020-7003	CHAMBER-FLOAT	1	1
16025	16025-7006	VALVE-THROTTLE	1	1
16030	16030-7003	VALVE-FLOAT	1	1
16031	16031-7002	FLOAT	1	1
16041	16041-7018	SHAFT-CARBURETOR,THROTTLE	1	1
16041A	16041-7049	SHAFT-CARBURETOR,CHOKE	1	1
16073	16073-7007	INSULATOR	1	1
16186	16186-7001	VALVE-ASSY-CHOKE	1	1
39076	39076-7001	LIMITER	1	1
49121	49121-7021	NOZZLE-MAIN	1	1
59076	59076-7020	MANIFOLD-INTAKE	1	1
92004	92004-7027	STUD,6X95		2
92004A	92004-7027	STUD,6X95	2	
92009	92009-2083	SCREW	2	2
92009A	92009-2349	SCREW	1	1
92063	92063-7046	JET-MAIN,#100,3280FT	AR	AR
92063A	92063-7047	JET-MAIN,#098,6560FT	AR	AR
92063B	92063-7156	JET-MAIN,#102	1	1
92081	92081-2234	SPRING	1	1
92093	92093-2100	SEAL	2	2
92145	92145-7015	SPRING	1	1
92145A	92145-7061	SPRING	1	1
92172	92172-7002	SCREW	1	1
92200	92200-2061	WASHER,9.8X5.5X1.0	1	1
130	130AA0635	BOLT-FLANGED,6X35	4	4
172	172BA0695	BOLT-STUD,6X95	*	

This catalog covers:
FS481V- □ S10

GRID NO. This grid covers:
B-11 AIR-FILTER/MUFFLER

E0190-B230A

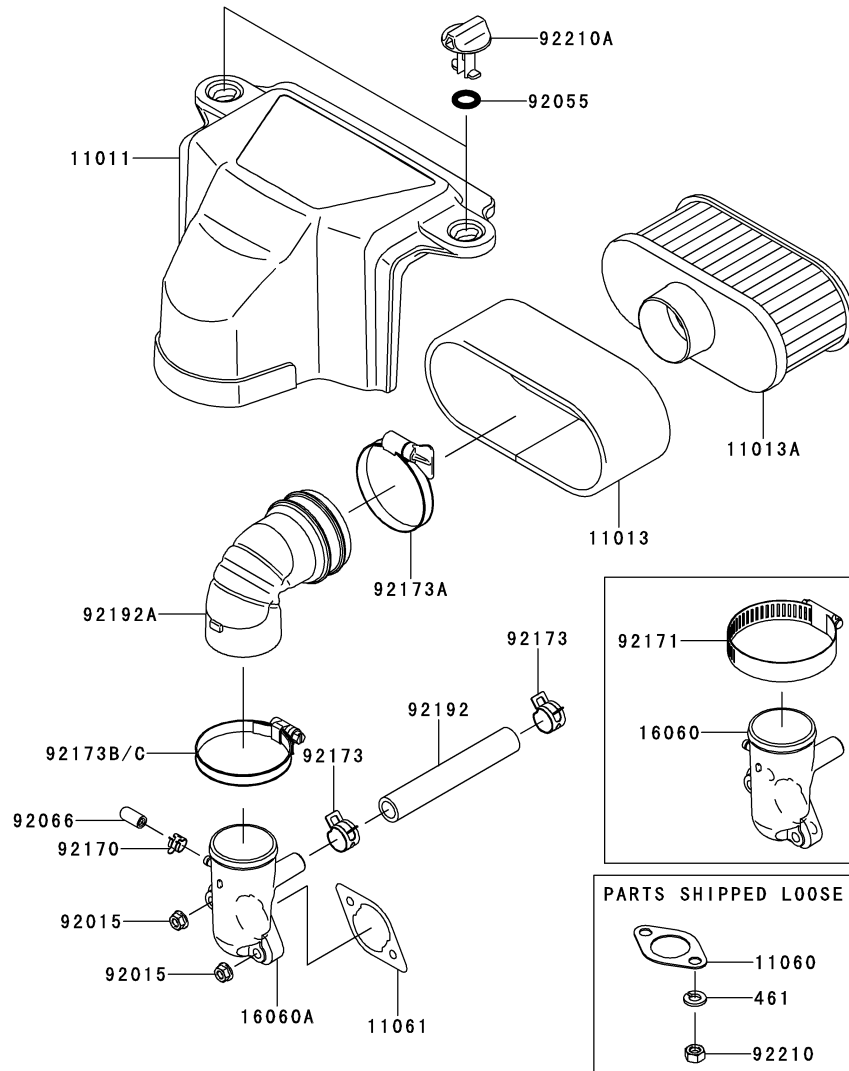

Ref. No.	Part No.	Description	Quantity	
			A	B
11011	11011-7064	CASE-AIR FILTER	1	1
11013	11013-7046	ELEMENT-AIR FILTER	1	1
11013A	11013-7049	ELEMENT-AIR FILTER	1	1
11060	11060-7016	GASKET,MUFFLER	2	2
11061	11061-7095	GASKET,AIR CLEANER	1	1
16060	16060-7036	PIPE-INTAKE	1	
16060A	16060-7039	PIPE-INTAKE		1
92015	92015-1367	NUT	2	2
92055	92055-7025	RING-O	2	2
92066	92066-0095	PLUG		1
92170	92170-2042	CLAMP		1
92171	92171-7010	CLAMP	*	
92173	92173-7003	CLAMP	2	2
92173A	92173-7007	CLAMP	1	1
92173B	92173-7009	CLAMP		1
92173C	92173-7009	CLAMP	1	
92192	92192-7146	TUBE,12.6X18.6X118	1	1
92192A	92192-7164	TUBE,A/C	1	1
92210	92210-7027	NUT,M8	4	4
92210A	92210-7038	NUT	2	2
461	461DA0800	WASHER-SPRING,8MM	4	4

This catalog covers:

FS481V- □ S10

GRID NO.

C-03

This grid covers:

STARTER

E0210-A550A

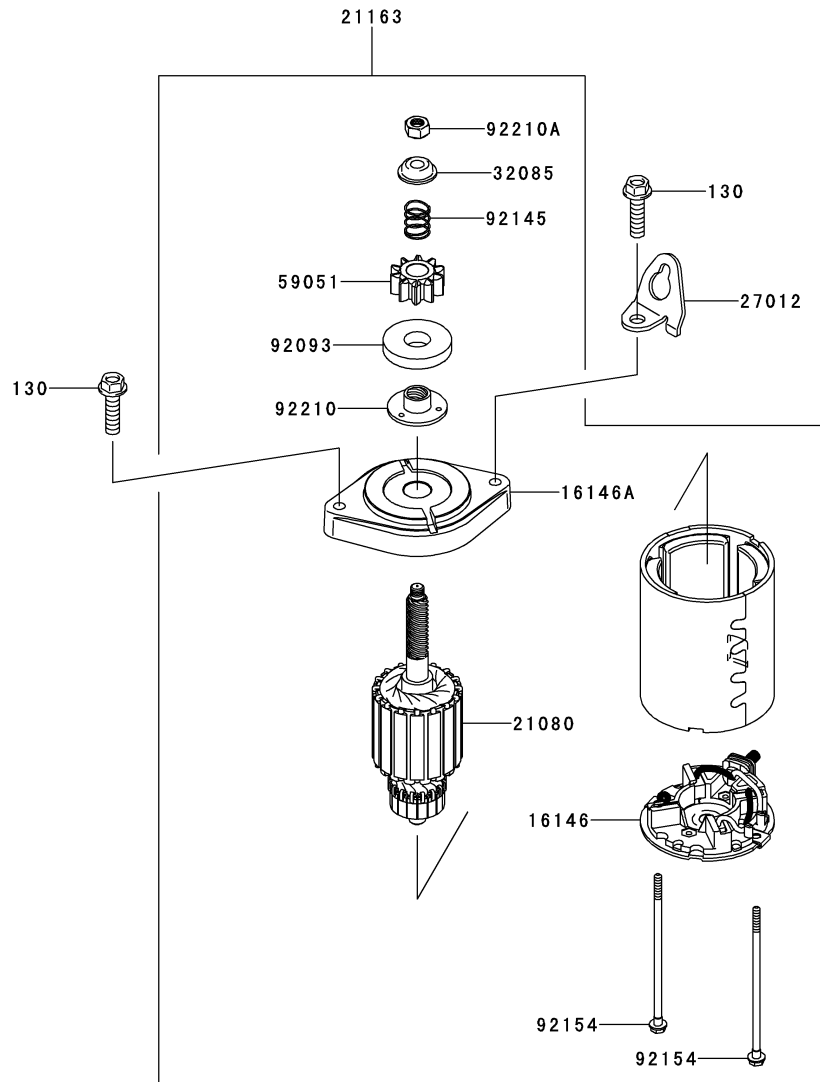

Ref. No.	Part No.	Description	Quantity	
			A	B
16146	16146-7027	COVER-ASSY	1	1
16146A	16146-7030	COVER-ASSY	1	1
21080	21080-7008	ARMATURE	1	1
21163	21163-0711	STARTER-ELECTRIC	1	1
27012	27012-7008	HOOK	1	1
32085	32085-7005	STOPPER	1	1
59051	59051-7034	GEAR-SPUR	1	1
92093	92093-7007	SEAL	1	1
92145	92145-7060	SPRING	1	1
92154	92154-7001	BOLT	2	2
92210	92210-7017	NUT	1	1
92210A	92210-7040	NUT,5/16-24	1	1
130	130AA0830	BOLT-FLANGED,8X30	2	2

This catalog covers:
FS481V- □ S10

GRID NO. This grid covers:
D-03 LABEL

F0290-B469A

Ref. No.	Part No.	Description	Quantity	
			A	B
56033	56033-7001	LABEL-MANUAL	1	1
56070	56070-7001	LABEL-WARNING	1	1

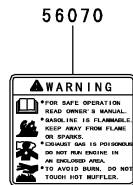
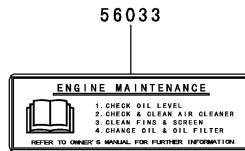

This catalog covers:

FS481V- □ S10

GRID NO.

H-09

This grid covers:

PART NAME INDEX

AIR-FILTER/MUFFLER.....	B-11
CARBURETOR.....	B-10
CONTROL-EQUIPMENT.....	B-09
COOLING-EQUIPMENT.....	B-07
CYLINDER/CRANKCASE.....	B-03
ELECTRIC-EQUIPMENT.....	B-08
LABEL.....	D-03
LUBRICATION-EQUIPMENT.....	B-06
PISTON/CRANKSHAFT.....	B-04
STARTER.....	C-03
VALVE/CAMSHAFT.....	B-05

This catalog covers:

FS481V- □ S10

GRID NO.

H-10

This grid covers:

NUMERICAL PARTS INDEX

Part No.	Grid No.	Part No.	Grid No.	Part No.	Grid No.	Part No.	Grid No.	Part No.	Grid No.
11004-7027.....	B-03	16073-7007.....	B-10	59071-7004.....	B-06	92153-7054.....	B-03		
11008-7050.....	B-03	16126-7020.....	B-03	59071-7023.....	B-06	92153-7100.....	B-05		
11008-7051.....	B-03	16146-7027.....	C-03	59071-7023.....	B-06	92154-7001.....	C-03		
11011-7064.....	B-11	16146-7030.....	C-03	59076-7020.....	B-10	92154-7003.....	B-08		
11013-7046.....	B-11	16154-7010.....	B-06	59231-7016.....	B-06	92154-7003.....	B-08		
11013-7049.....	B-11	16154-7011.....	B-06	670B2011.....	B-03	92170-2042.....	B-11		
11022-7019.....	B-03	16171-7025.....	B-09	670D2016.....	B-06	92170-2088.....	B-03		
11022-7020.....	B-03	16186-7001.....	B-10	92004-7027.....	B-10	92170-7001.....	B-09		
11055-7009.....	B-05	172BA0695.....	B-10	92004-7027.....	B-10	92171-7010.....	B-11		
11060-7016.....	B-11	172BA0818.....	B-03	92009-2083.....	B-10	92172-7002.....	B-10		
11061-7009.....	B-10	21066-7017.....	B-08	92009-2303.....	B-08	92172-7018.....	B-08		
11061-7010.....	B-10	21080-7008.....	C-03	92009-2349.....	B-10	92173-7003.....	B-11		
11061-7083.....	B-03	21163-0711.....	C-03	92015-1367.....	B-11	92173-7007.....	B-11		
11061-7089.....	B-10	21171-7047.....	B-08	92033-7001.....	B-05	92173-7009.....	B-11		
11061-7094.....	B-03	21193-7038.....	B-08	92033-7002.....	B-04	92173-7009.....	B-11		
11061-7095.....	B-11	214AA0408.....	B-03	92039-7004.....	B-07	92192-7146.....	B-11		
11061-7096.....	B-10	214AA0408.....	B-09	92043-1263.....	B-03	92192-7164.....	B-11		
11065-7005.....	B-10	26011-7025.....	B-08	92049-7001.....	B-03	92200-2061.....	B-10		
12004-7009.....	B-05	26031-7040.....	B-08	92049-7005.....	B-03	92200-2151.....	B-05		
12005-7010.....	B-05	27012-0721.....	B-03	92049-7010.....	B-03	92200-7002.....	B-08		
12009-7001.....	B-05	27012-7007.....	B-03	92049-7028.....	B-03	92200-7009.....	B-05		
12011-2056.....	B-05	27012-7008.....	C-03	92055-7025.....	B-11	92200-7048.....	B-05		
12016-2066.....	B-05	311AA0600.....	B-09	92063-7046.....	B-10	92210-7017.....	C-03		
12032-7001.....	B-05	312AA0500.....	B-09	92063-7047.....	B-10	92210-7027.....	B-11		
13001-7028.....	B-04	312AA0600.....	B-05	92063-7156.....	B-10	92210-7038.....	B-11		
13001-7031.....	B-04	32085-7005.....	C-03	92066-0095.....	B-11	92210-7040.....	C-03		
13001-7031.....	B-04	32154-7019.....	B-03	92066-2096.....	B-03				
13002-7001.....	B-04	32155-7003.....	B-03	92066-7006.....	B-06				
13008-7006.....	B-04	39076-7001.....	B-10	92066-7023.....	B-03				
13025-7010.....	B-04	39129-7033.....	B-09	92066-7026.....	B-03				
13029-7011.....	B-04	411AA0600.....	B-09	92066-7026.....	B-08				
13031-7090.....	B-04	42036-7010.....	B-05	92066-7028.....	B-06				
13070-7017.....	B-05	42036-7021.....	B-05	92070-7004.....	B-08				
130AA0620.....	B-08	42036-7021.....	B-05	92072-7003.....	B-08				
130AA0625.....	B-03	461DA0800.....	B-11	92081-2234.....	B-10				
130AA0635.....	B-10	49015-7083.....	B-03	92093-2100.....	B-10				
130AA0814.....	B-05	49015-7104.....	B-03	92093-7007.....	C-03				
130AA0830.....	C-03	49015-7104.....	B-03	92104-7001.....	B-03				
130CA0870.....	B-03	49065-7006.....	B-06	92140-7003.....	B-06				
13107-7018.....	B-10	49065-7007.....	B-06	92140-7005.....	B-05				
13107-7049.....	B-09	49078-7002.....	B-05	92145-7001.....	B-05				
13116-7008.....	B-05	49089-7083.....	B-07	92145-7002.....	B-06				
13251-7021.....	B-04	49089-7084.....	B-07	92145-7004.....	B-09				
13271-7007.....	B-05	49103-7017.....	B-09	92145-7015.....	B-10				
13271-7021.....	B-05	49113-0716.....	B-09	92145-7057.....	B-09				
13271-7038.....	B-09	49113-0716.....	B-09	92145-7060.....	C-03				
13272-7004.....	B-03	49113-7061.....	B-09	92145-7061.....	B-10				
13272-7011.....	B-06	49118-7023.....	B-05	92150-2182.....	B-09				
14075-7013.....	B-06	49120-7135.....	B-03	92151-2097.....	B-08				
14091-7064.....	B-03	49121-7021.....	B-10	92151-7014.....	B-09				
15004-7086.....	B-10	510A5100.....	B-08	92151-7017.....	B-04				
16014-7011.....	B-10	55020-7015.....	B-07	92152-7020.....	B-05				
16020-7003.....	B-10	555A0420.....	B-06	92152-7022.....	B-05				
16025-7006.....	B-10	56033-7001.....	D-03	92152-7022.....	B-05				
16030-7003.....	B-10	56070-7001.....	D-03	92153-7007.....	B-07				
16031-7002.....	B-10	59031-7017.....	B-08	92153-7008.....	B-06				
16041-7018.....	B-10	59041-7016.....	B-07	92153-7033.....	B-09				
16041-7049.....	B-10	59051-7034.....	C-03	92153-7043.....	B-03				
16060-7036.....	B-11	59066-7055.....	B-07	92153-7043.....	B-06				
16060-7039.....	B-11	59071-2079.....	B-03	92153-7043.....	B-09				